

# SEBS-B/SEBS-BY Type SEBS-BM/SEBS-BYM Type

— Retained Ball Type —

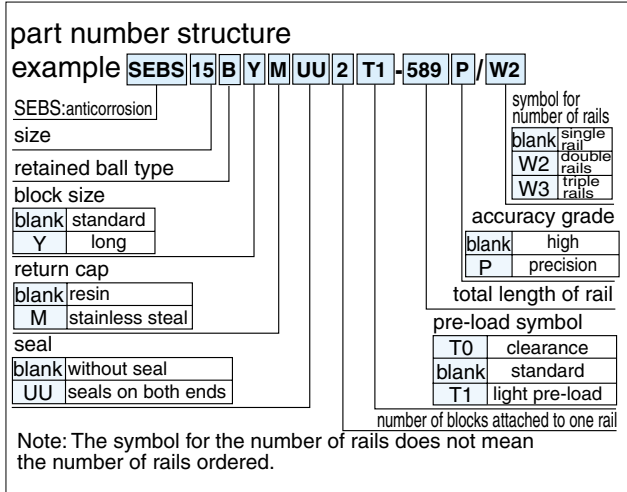

SEBS-B Type

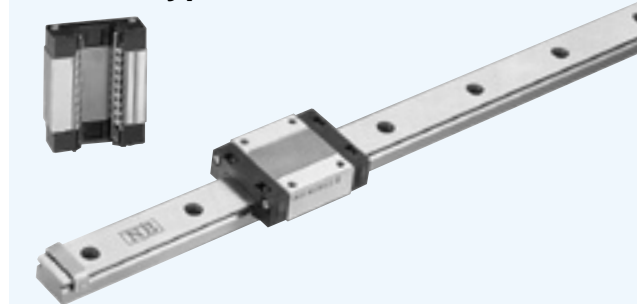

SEBS-BM Type

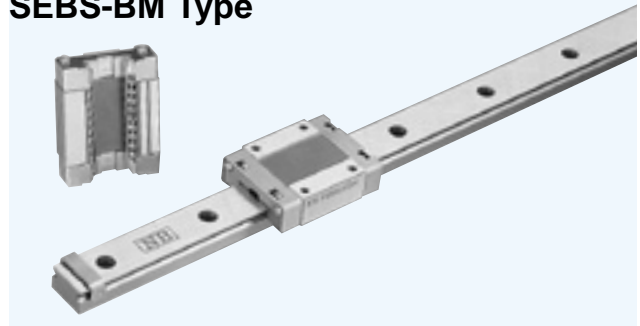

part number		assembly dimensions		block dimensions								
		H	W	B	L <sub>1</sub>	L <sub>2</sub>	P <sub>1</sub>	P <sub>2</sub>	S <sub>1</sub>	ℓ	L <sub>3</sub>	b
resin return cap	stainless return cap	mm	mm	mm	mm	mm	mm	mm	mm	mm	mm	mm
<b>SEBS 5B</b>	<b>SEBS 5BM</b>	6	3.5	12	16.3	16.7	8	—	M2	1.5	9.3	4.5
<b>SEBS 5BY</b>	<b>SEBS 5BYM</b>				19.3	19.7		—			7	
<b>SEBS 7B</b>	<b>SEBS 7BM</b>	8	5	17	23	23	12	8	M2	2.5	12.8	6.5
<b>SEBS 7BY</b>	<b>SEBS 7BYM</b>				32.5	32.5		13			22.3	
<b>SEBS 9B</b>	<b>SEBS 9BM</b>	10	5.5	20	30.8	30.8	15	10	M3	3	19.6	7.8
<b>SEBS 9BY</b>	<b>SEBS 9BYM</b>				40.3	40.3		16			29.1	
<b>SEBS 12B</b>	<b>SEBS 12BM</b>	13	7.5	27	33.8	34.2	20	15	M3	3.5	20.2	10
<b>SEBS 12BY</b>	<b>SEBS 12BYM</b>				45.7	46.1		20			32.1	
<b>SEBS 15B</b>	<b>SEBS 15BM</b>	16	8.5	32	41.6	42	25	20	M3	4	26.6	12
<b>SEBS 15BY</b>	<b>SEBS 15BYM</b>				57.5	57.9		25			42.5	
<b>SEBS 20B</b>	<b>SEBS 20BM</b>	25	13	46	65.9	65.9	38	38	M4	6	44.7	17.5
<b>SEBS 20BY</b>	<b>SEBS 20BYM</b>				85.7	85.7		38			64.5	

※1 Custom mounting bolts are provided for SEBS 5. (See Page6)

rail size	standard rail length											
	L mm											
<b>5</b>	40	55	70	85	100	130	160					
<b>7</b>	40	55	70	85	100	130	160	190	220	250	280	310
<b>9</b>	55	75	95	115	135	155	175	195	235	275	315	355
<b>12</b>	70	95	120	145	170	195	220	245	270	295	320	345
<b>15</b>	70	110	150	190	230	270	310	350	390	430	470	510
<b>20</b>	220	280	340	400	460	520	580	640	760	880	1,000	

With custom length rails, kindly advise distance (N) from one end of rail to first hole.

Unless we are advised (N) distance by customer, we assume distance (N) to be as state in Page4.

Joint rails are used when the required length exceeds the maximum standard length listed in the dimensional tables contact NB for details.

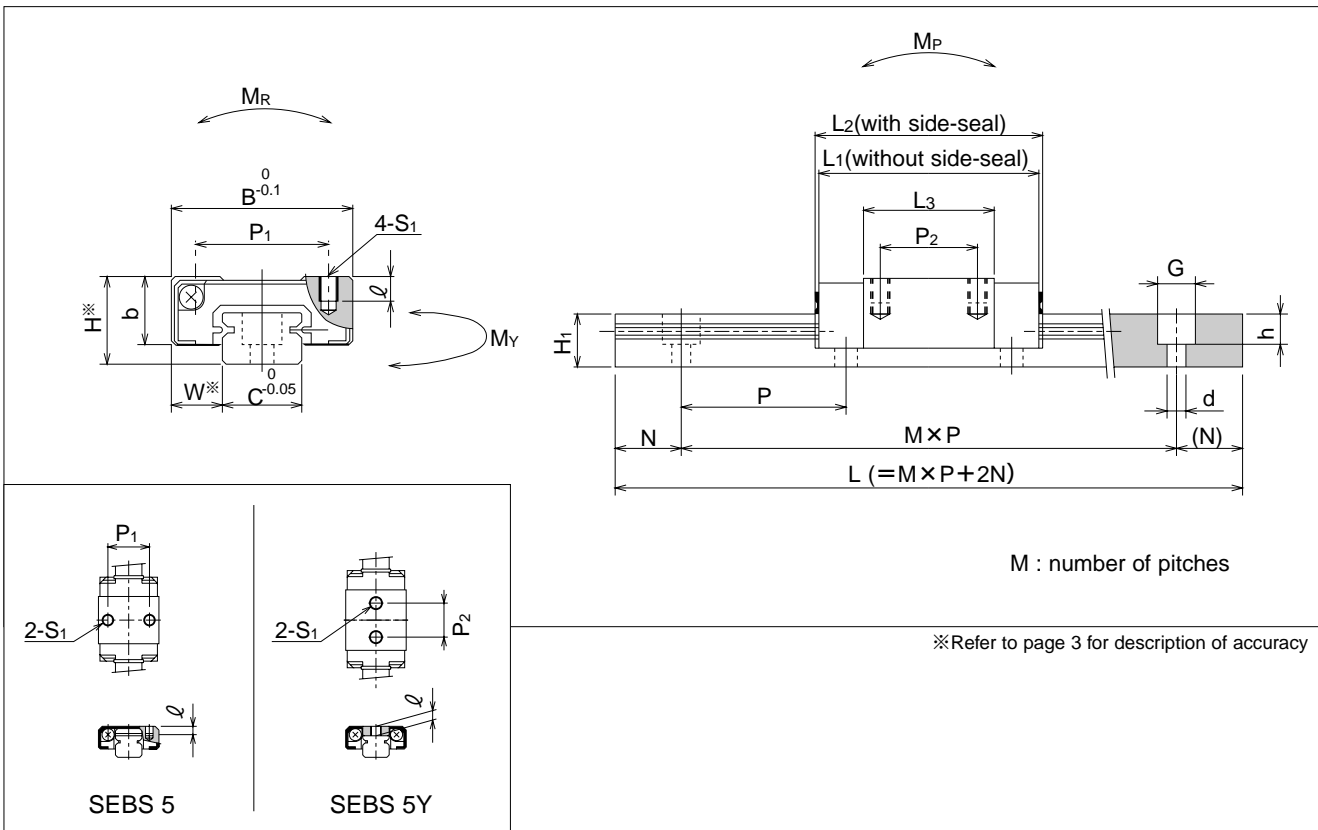

guide-rail dimensions					basic load rating		allowable static moment			mass		block size	
H <sub>1</sub>	C	d × G × h	N	P	dynamic	static	M <sub>P</sub>	M <sub>Y</sub>	M <sub>R</sub>	resin return cap	stainless return cap		
mm	mm	mm	mm	mm	kN	kN	N · m	N · m	N · m	kg	kg/m		
4	5	2.4 × 3.5 × 0.8 <sup>※1</sup>	5	15	0.39	0.66	0.9	0.8	1.7	0.003	0.004	0.13	5B
					0.52	0.88	1.7	1.4	2.2	0.004	0.005		5BY
4.7	7	2.4 × 4.2 × 2.3	5	15	1.10	1.70	3.5	3.0	6.2	0.009	0.011	0.19	7B
					1.93	2.98	11.0	9.3	10.8	0.015	0.017		7BY
5.5	9	3.5 × 6 × 3.5	7.5	20	1.67	2.47	7.8	6.6	11.5	0.02	0.02	0.31	9B
					2.47	3.70	17.6	14.9	17.2	0.03	0.03		9BY
7.5	12	3.5 × 6 × 4.5	10	25	2.55	3.70	11.7	9.9	23.1	0.03	0.04	0.61	12B
					4.15	6.02	31.0	26.3	37.6	0.05	0.06		12BY
9.5	15	3.5 × 6 × 4.5	15	40	4.26	6.36	26.9	22.8	49.2	0.06	0.08	1.02	15B
					6.92	10.3	71.1	60.2	80.1	0.10	0.11		15BY
15	20	6 × 9.5 × 8.5	20	60	8.91	12.7	92.7	78.5	130	0.23	0.27	2.14	20B
					12.9	18.5	195	165	189	0.32	0.36		20BY

1kN ≒ 102kgf    1N · m ≒ 0.102kgf · m

395	435	475			
370	395	420	445	470	495
550	590	630	670		