

Air-Powered Gearmotors

8AM Series, 20:1 reduction, 400 – 2550 lbs. in. (50 – 290 Nm) torque at 15 rpm (minimum speed reduction)



MODEL

8AM-32A-FB20

(8 Vanes, Reversible)

Net wt. for standard configuration
111 lbs. (50,0 kg)

FEATURES

- 20:1 gear reducer
- Base mounting
- Optional mountings and shaft locations available
- Muffler AC990 (not shown)

RECOMMENDED

- Filter AH106F
- Regulator AH107R
- Gauge AA806
- Lubricator AH108L
- Muffler AG600 (above 1,000 rpm)
- Oil AD220 – 1 quart (.94 litres)
- Repair kit K282 (Air motor only)

OPTIONAL

- Muffler AL476 (for additional noise reduction)

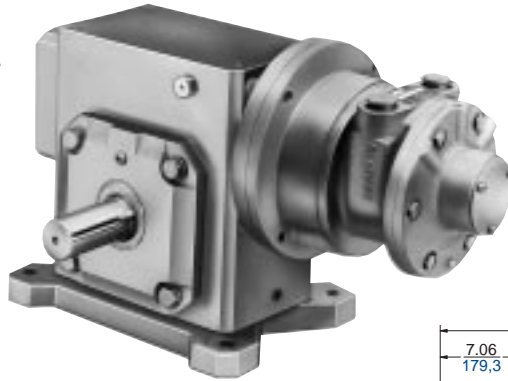

Max. allowable end thrust with 0 overhung load is 3552 lbs. (1598,4 kg) at 30 rpm to 2154 lbs. (969,3 kg) at 125 rpm. Max. overhung load on output shaft with 0 end thrust 2857 lbs. (1285,7 kg).

"B" Mounting (photo)
8AM-32A-FB20 / 8AM-32A-FF20
(standard shaft) / (opposite shaft)

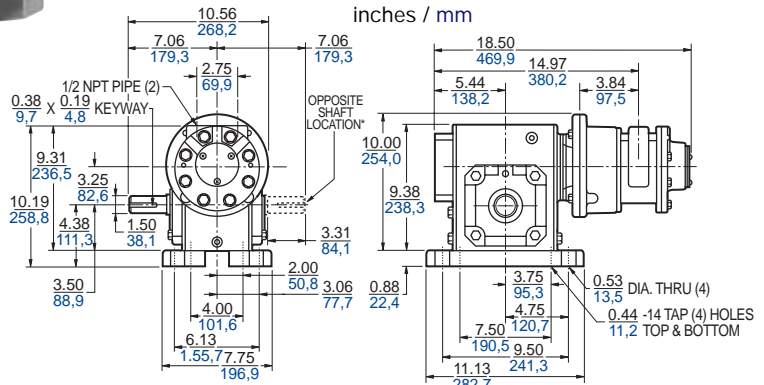

Output Power vs. Speed

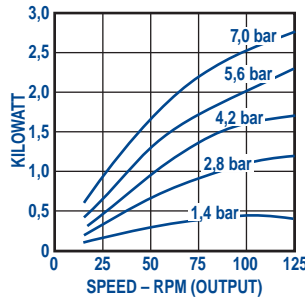
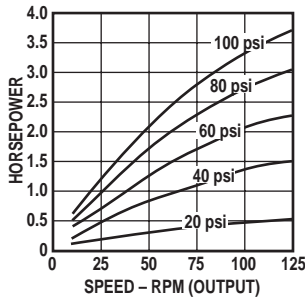

Torque vs. Speed

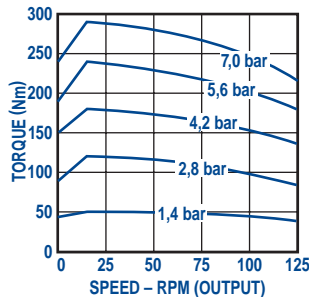
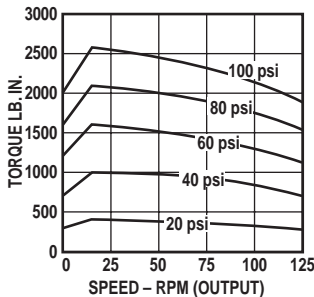

"C" Mounting

8AM-32A-FC20

inches / mm

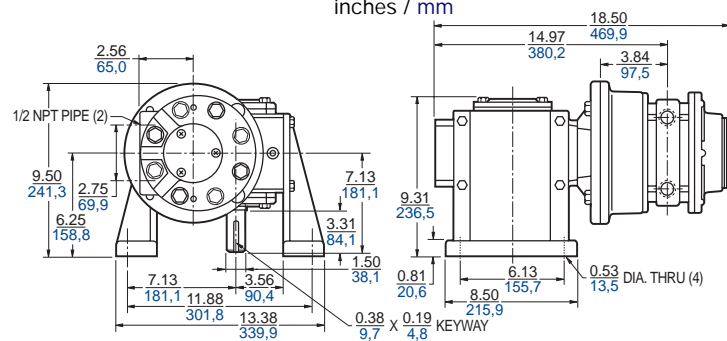

"D" Mounting

8AM-32A-FD20

inches / mm

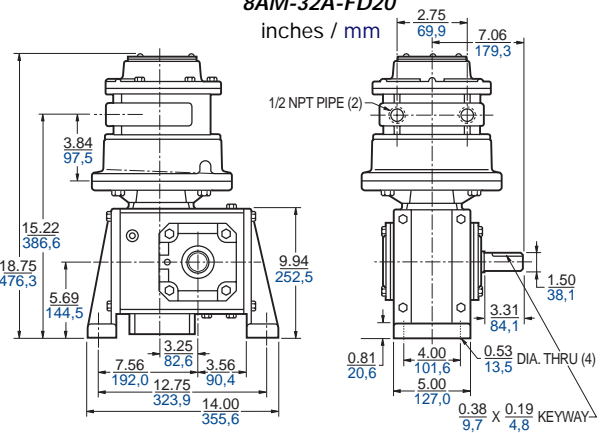

Air Consumption vs. Speed

